



**P&F Technology**  
CONSTRUYENDO CONFIANZA

# PROCESS & FLUIDS TECHNOLOGY SpA

**ANÍBAL PINTO 372 OF. 63 - CONCEPCIÓN, CHILE**

[contacto@pftech.cl](mailto:contacto@pftech.cl)

[www.pftech.cl](http://www.pftech.cl)



# ISO 9001:2015 CERTIFIED COMPANY





# SUBSCRIBED BRANDS





**P&F Technology**  
CONSTRUYENDO CONFIANZA

# BUILDING TRUST.



**SOLVING YOUR  
PROBLEMS IS OUR  
GOAL**





# PLATE, JOINT AND PLATE HEAT EXCHANGERS CERTIFIED



Supply of parts for branded equipment  
Alfa Laval, APV, Sondex, Gea, Tranter, etc.,  
in different materials (SS304, SS316,  
Titanium, Inconel and thicknesses (0.4, 05,  
0.7mm),  
Gaskets for heat exchangers  
plates in: EPDM, NBR, HNBR, HYPALON and  
others, according to the needs of our  
customers.



# WELDED EXCHANGERS

## CERTIFICATIONS: ISO 9001 AND ISO 14001





# EXPANSION JOINTS METALLIC





# JUNTAS DE EXPANSIÓN ELASTOMÉRICAS

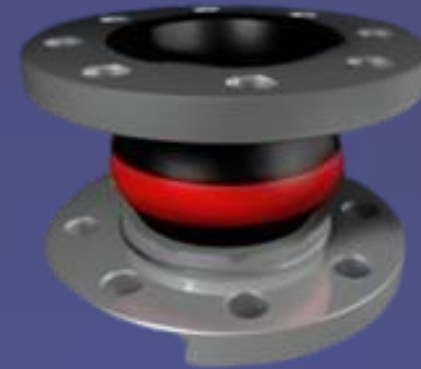
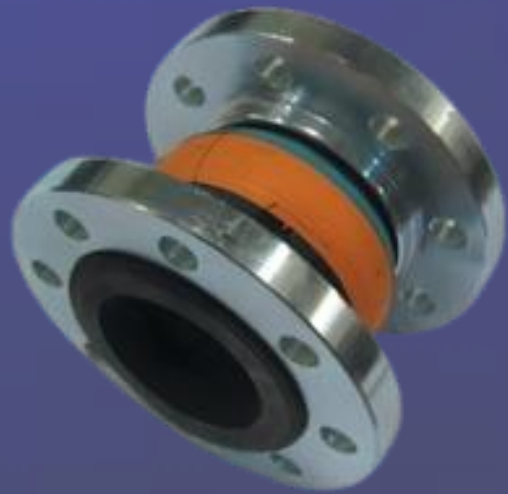





# VALVES DIFFERENT APPLICATIONS AND MATERIALS: DIAPHRAGM, GATE, BUTTERFLY.





# VALVES

## DIFFERENT APPLICATIONS AND MATERIALS: BALL, GLOBE.

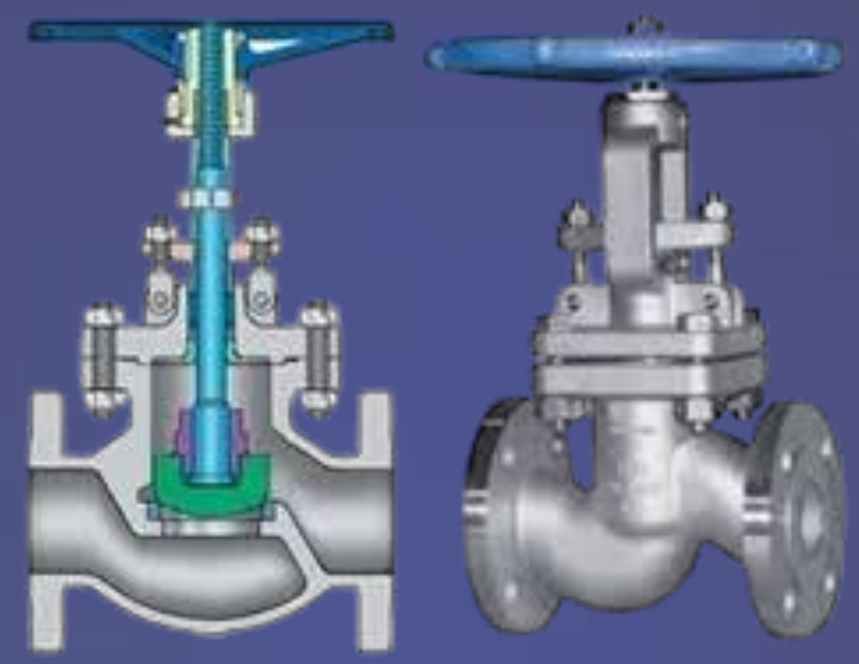



**P&F Technology**  
CONSTRUYENDO CONFIANZA

# PALLET PUMPS, PISTON, WELL.

**REXROTH**



**VICKERS**



**GRUNDFOS**





**P&F Technology**  
CONSTRUYENDO CONFIANZA

# PUMPS, DOSING, PERISTALTIC, VACUUM.

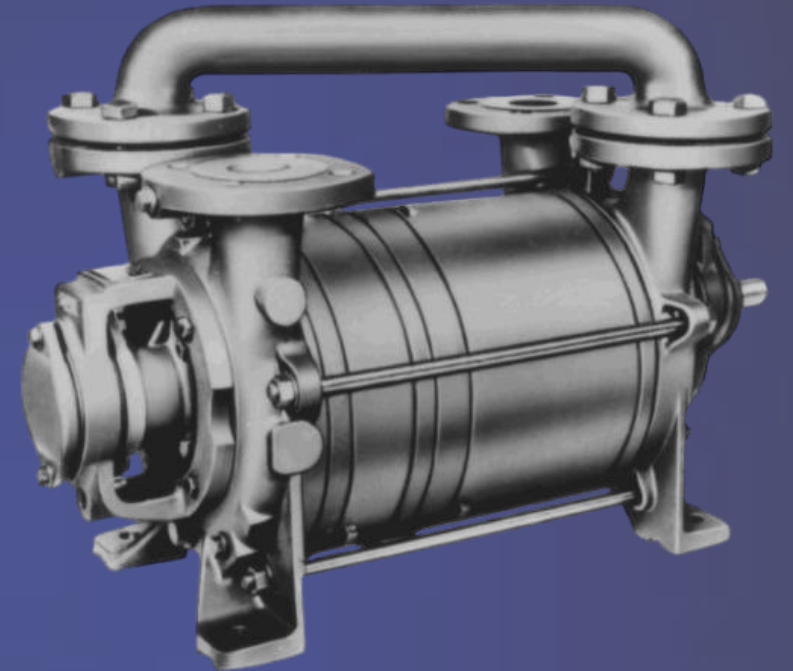
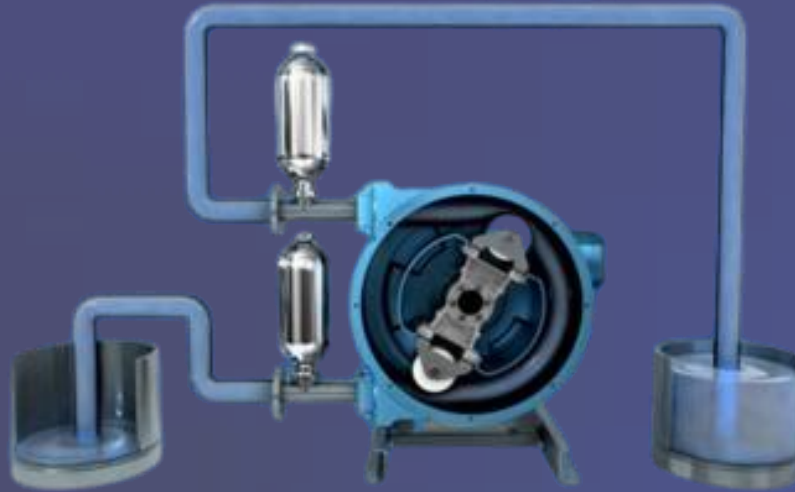



**P&F Technology**  
CONSTRUYENDO CONFIANZA

# ENGINEERING PRODUCTS BLOWERS, FANS AND SHOCK ABSORBERS





# PROCESS & FLUIDS TECHNOLOGY SpA



**CREATING ALLIANCES  
COMMERCIAL TECHNICIAN**